

Classic Mac Repair Notes

1.0 Introduction

With each passing day, more classic Macs act their age by dying. Fortunately, most failures are relatively easy to correct, so if you're willing to put in a little effort, you can save many of them from the landfill. And you don't have to be a super-tech, either. You can perform most of these repairs with simple, inexpensive tools.

As with any product, compact Macs suffer from a few design flaws that make certain failures more likely than others. Fortunately, all of these have been well documented by now, and so have their solutions. We'll focus mainly on those well known defects that are responsible for the majority of the problems you're probably going to encounter. Although these notes are mainly for the 128K, 512K and Plus, many of the general troubleshooting tips also apply to the SE, SE/30 and Classic/Classic II. Except for minor variations, the analog board for the Plus described here is the same as that used in earlier models. Also, the horizontal and video circuits are virtually identical to those used in the SE and SE/30 (but the vertical and power supply circuits are *completely* different).

2.0 Preliminaries

2.1 Safety

Obviously, it's *very* dangerous to work on the innards of any line-powered electronic equipment if the unit is still plugged in. So, before you do anything, **UNPLUG IT**. Don't rely on the on/off switch -- **actually remove the power cord**. Repeat: **Pull out the cord**. Got that? *Out with the cord*. If you must work on the unit "hot" for some reason, please pay attention in what follows to notes on how to reduce the risk of killing yourself. A compact Mac by itself may be small, but your power company is very, very strong. **Pull out the cord**. This warning brought to you by the Department of Redundancy Department.

Unless you are going to work on the HV circuitry, it's best *not* to discharge the CRT, contrary to most written advice (including Apple's). The reason is simple: You have to expose yourself to the possibility of contact with HV to do so. If you make a mistake, you will receive an unpleasant (but not lethal, despite what a lot of people say) shock. Or, the discharge might take a path through delicate components and damage them. Since the HV wiring is very well insulated, you will be well protected if you simply leave it alone.

To reduce the risk of getting shocked, let the unit sit unplugged for a day or two. If the Mac is healthy enough to light up the screen, you can speed up the process by turning up the brightness, and then unplugging the Mac while it's still powered on (yes, this is a little rough on disk drives, so make certain that no disk activity is happening). The current drawn from the HV supply by the still-functioning circuit will rapidly discharge the HV.

2.2 Opening up the Mac

You'll need a *very* long mutant Torx-15 driver to open up a compact Mac. Two screws are in the deep recess along the top, and another two are on the back panel, straddling the connector array on the bottom. For the 128K, 512K and Plus, there's also a fifth screw, hidden inside the battery compartment.

Once all the screws are out, hold the Mac with the CRT facing down, a couple of inches over a soft surface (carpet is good). Holding the unit by the rear cover alone, give it a vigorous shaking until the cover works loose from the rest of the unit. The two case halves can be very tightly joined, so expect a little bit of a struggle. Just be patient.

Don't use a screwdriver, or you'll chew up the case. Special "case crackers" exist, but I find that the "shake it until the front falls out" method works fine.

3.0 Anatomy of a Plus

Ok, you've got the case apart, and the glorious innards are exposed (the power cord is still unplugged from the Mac, right?). Here's a quick look at some popular tourist destinations:

FIGURE 1. CRT and analog board

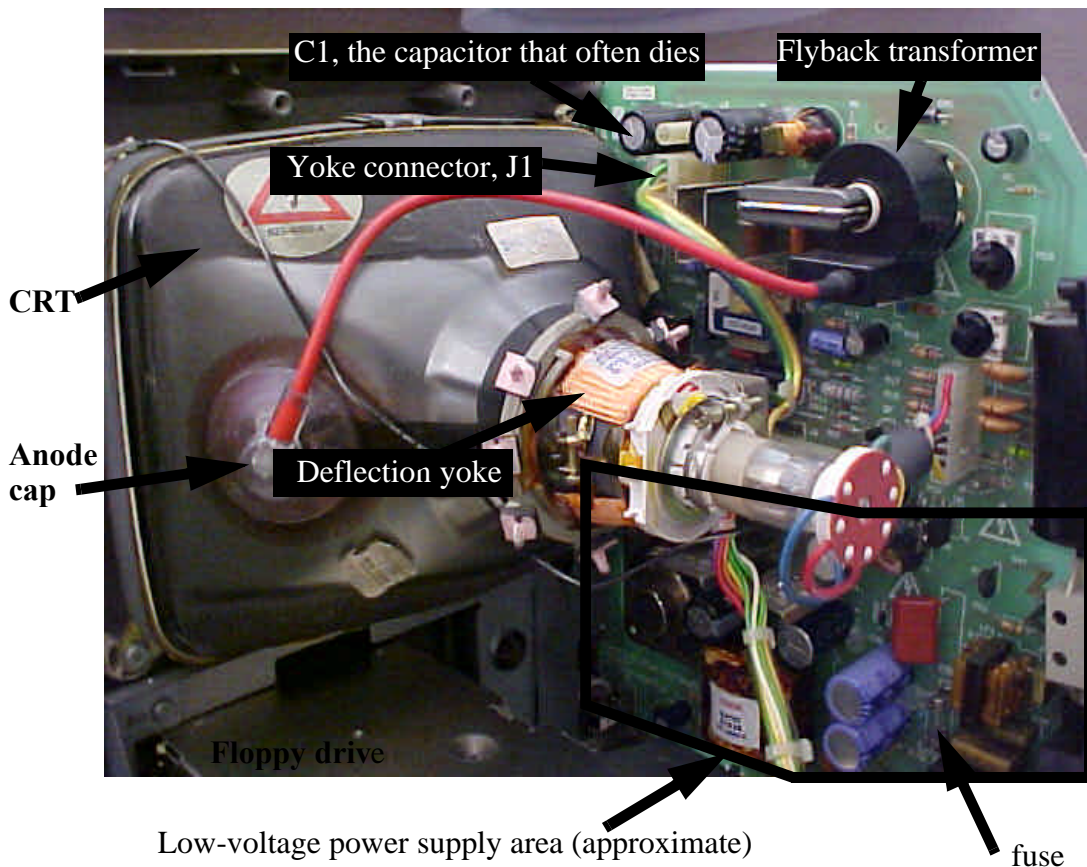

Some of the components you may be working with are identified in the photo. One is the yoke connector (the yoke gets its name from the fact that it sits around the neck of the CRT, just as a conventional yoke sits on the necks of oxen). Many common problems are caused by a bad yoke connector and/or its solder joints.

The anode cap contains what makes the high-voltage connection to the CRT. There are no exposed high-voltage terminals; everything is very well insulated, so unless somebody has physically damaged the high-voltage lead, casual contact should not result in a shock. And again, any shock that you might get would not be dangerous (but certainly unpleasant), so there's no need to worry excessively about it.

The high-voltage ("flyback") transformer, is one famously weak spot in the design of compact Macs. Unfortunately undersized to begin with, the lack of a fan only accelerates its demise. Heat is the enemy of electronics, and the flyback surrenders readily.

Another common victim of prolonged exposure to heat is capacitor C1 (labeled in the photo as "the capacitor that often dies"). As we'll explain later, the original designer chose the wrong capacitor type for C1. Frankly, it's amazing that they work as long as they typically do.

There is one fuse on the analog board. It's part of the low-voltage power supply, and generally won't blow unless a serious fault has occurred. In rare cases, it will simply blow out from fatigue over time, but more likely, you have some serious troubleshooting ahead.

We'll delve into all the why's and how's momentarily. We just wanted to give you a quick tour of the key landmarks before diving into the details.

4.0 Common problems and their cures

4.1 No display; Wobbly display; Single vertical line down the middle

If the Mac seems to function well (e.g., you hear the boot bong, disk accesses occur the way they should, etc.), but has certain display problems, this section is for you. Many display-related problems are due to the **notoriously** unreliable solder joints on the yoke connector J1. These should *always* be resoldered as a matter of course because a visual inspection does not always reveal problems such as hairline cracks. Flakiness here results in symptoms that include an intermittent raster, wobbly/shaky/jittery raster, no raster, uncorrectably narrow raster, or a single vertical line down the center of the CRT. Quite commonly, slapping the side of the Mac can make these symptoms come and go if the connector is indeed the problem. Without question, this is the most common fault with the analog board. It's sad that so many old Macs are tossed in the trash because of this problem, because it's trivial to fix, most of the time.

To repair, simply freshen up the yoke's four solder connections to the analog board, while **leaving the connector halves mated, or else the heat will melt the connector plastic**

and distort its shape. You'll never be able to reconnect the two halves if you fail to follow this advice.

And don't be lazy and simply reheat the old solder that's there -- **use new solder.** Use enough heat/duration to get the solder to flow well, leaving a shiny, smooth surface upon cooling. After it's cooled down, disconnect the two halves and inspect the four mating pairs of contacts for signs of oxidation or burning. Repair or replace as necessary. If you can't locate a replacement (or don't want to wait for one), you can always simply hard-wire the connections (e.g., desolder J1 from the analog board, remove its mate from the yoke cable assembly, and just solder the four yoke wires directly to the analog board). The drawback is that if you need to remove the analog board later for some reason, you'll have to undo the connections.

FIGURE 2. Closeup of yoke connector, J1

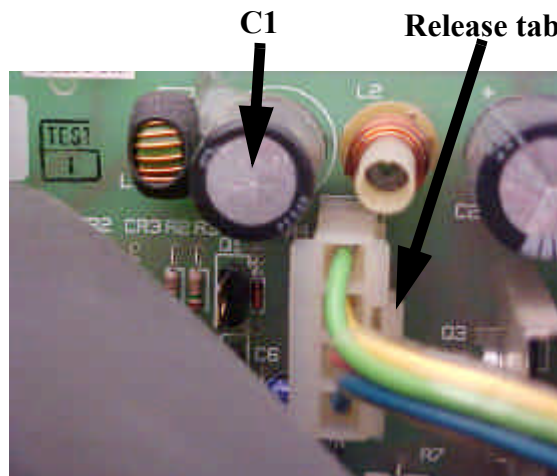

To disengage the connector, squeeze on the release tab and pull the top half out from the bottom half. Needlenose pliers are helpful here. The connector may be difficult to loosen, so don't be surprised if you have to struggle a little bit. Just be patient and work carefully and gently. If you rush, you run the risk of a sudden release, and you might hurt yourself (or the Mac) if you strike something.

Whether or not refreshing J1's solder joints fixes your display problem, take a close look at capacitor C1. Depending on model and production date, it will be either a 3.9 or 4.7 μ F (microfarad) **nonpolar** electrolytic capacitor (the value is not terribly critical in this particular case). The top metal should be **flat**. If it bulges visibly, it's dead; no need to do any further checking at all. Also check for bulging on the bottom, where it touches the PC board (sometimes this is hard because of the massive amounts of hot glue often present). Replace it **only** with a **nonpolar**, low loss (**low ESR** -- that's *effective series resistance*) unit rated at 50V or more. Do *not* replace this capacitor with the same type as the original. The circuit desperately needs a low loss capacitor, because large high-frequency currents are flowing through it. Unfortunately, the original choice isn't up to snuff. What's worse, its effective series resistance grows at the higher temperatures found in the fanless compact Macs. In turn, the temperature of the capacitor goes up, which causes its resistance to go up, which causes the temperature to go up, which...well, you get the picture.

A suitable replacement capacitor can be a little difficult to locate on occasion, however, so if you don't mind altering the appearance of the board, you may substitute a parallel combination of four or five 1.0 μ F ceramic disk capacitors, rated at 50V breakdown or more (there's plenty of room; build it up as a module of four caps, and use two pieces of bus wire to connect it to the pc board; secure with hot glue if you wish). Ceramic capacitors are readily available and inherently nonpolar. What's more, the parallel combination reduces the overall ESR to lower values than the commonly suggested replacements. Plus, whatever heat they generate is now spread out among the separate capacitors, reducing still further any temperature rise. This somewhat un-aesthetic solution is extremely robust.

Finally, freshen up the solder joints associated with the flyback transformer in the same way you freshened up J1's joints. Although problems here are much less frequent, I've run into a couple of cases. Give it a shot and see.

4.2 Power-supply related problems

The low-voltage power supply is another weak area in the original series of compact Macs. Again, part of the problem is the lack of a fan. The design is only truly happy at room temperature, so over time without a fan, the power supply can gradually cook itself into oblivion. This cooking can result in the failure of individual components, and it can also accelerate the oxidation of various connectors, resulting in flaky behavior.

A not uncommon problem is spontaneous and/or periodic reset. First eliminate one simple cause: Check to see if your Mac has the reset/interrupt button plastic gizmo installed on the side of the Mac. If so, verify that it hasn't gotten stuck in the reset position.

In other cases, the Mac seems to be humming along just fine, and then it suddenly reboots. At first this may occur only infrequently, making you think that there's a software problem. Later, it may get stuck in an endless boot-bong loop. These behaviors are almost always caused by insufficient voltage on the +5V supply line. What happens is this: If the voltage is, say, 4.6V, most of the circuitry might be ok when cold. As it heats up, maybe the voltage shifts, maybe the demand requirements change, but whatever the case, it resets. During reset, the load is minimum (because not much is happening), so the voltage is a bit higher and the Mac starts to boot. As things come up, they load the supply, and the voltage may dip low enough to trigger a reset. Bong! And on it goes.

Although this voltage may be adjusted by R56, you must resist the temptation to tweak the voltage adjust trimpot for now, otherwise you run the risk of turning a minor problem into a major meltdown. Here's why: The power supply produces several voltages simultaneously. It actually only monitors and controls the +12V supply directly. All of the other voltages are derived indirectly from it. If there's extra resistance in the 5V line that causes some voltage drop, that won't show up in the +12V supply, so it doesn't get corrected. Now, if you try to "fix" the problem by adjusting R56, you will be increasing the +12V supply voltage to compensate a 5V problem. When the 5V line is happy, the +12V line could be way over spec, causing bad things -- maybe irreversibly bad things -- to happen.

So tweaking R56 should be the *last* thing you do. The first thing is to disconnect the cable from J4 (see photo).

FIGURE 3. Location of J4

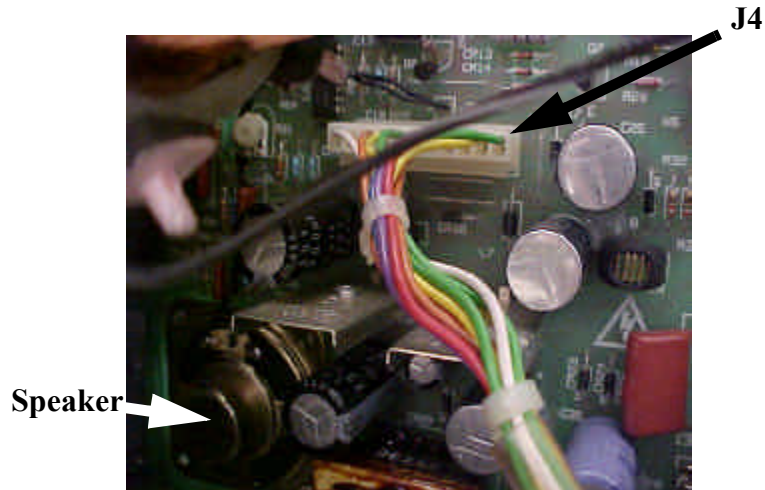

Once you've done that, clean the exposed contacts. There are lots of ways to clean terminals. Pros like to use a spray called Cramolin; it's good stuff. Just don't go wild. You don't need to flood the area. The weekend technician can get along fine without it, though. Just find yourself a pink pencil eraser (you know, the kind that sits on the end of a Ticonderoga No. 2 pencil). It's got just the right abrasiveness to do an excellent job in most cases. Just work carefully and slowly -- there's not a whole lot of space (if you feel too constrained, perhaps it's a good idea to pull out the analog board altogether). After you're done, carefully clear out all of the eraser residue and reassemble the connector. Then undo it. Repeat several times. The multiple cycles of connection/disconnection will clean up the hard-to-get-at contact surfaces. Nine times out of ten, this will fix the persistent reset problem.

Then adjust R56 if you want. The safest method is to measure the 5V supply voltage at the external floppy connector on back (details are in the next section, Basic Adjustments). If the 5V line can't be brought into spec without causing an overvoltage on the 12V line, you have more work to do to track down the source of additional voltage drop on the 5V supply. It may be a good idea to freshen up the solder joints on J4, much as is advised for J1.

Weak spots in the power supply design include the rectifiers CR20 and CR21, and the filter capacitors C24-C26 and C29-C31 (see schematics in the Appendix). They run too hot because of the absence of a fan, and this shortens life considerably. Common upgrades for the rectifiers are to use Motorola Schottky rectifier MBR1045 (10A, 45V) for CR20 and (ultra)fast recovery rectifier MUR410 (4A, 100V, 35ns) for CR21. Fast recovery rectifier CR22 has no documented history of unusual problems, presumably because the total current pulled from the -12V supply is low.

4.3 Damaged CRT

If the CRT has unacceptable screen burn or was damaged in shipping (or by an unfortunate slip of the hand during a repair attempt; it's easy to break the neck, and even easier to snap the vacuum seal nipple), you'll need to replace it. Doing so isn't too hard, but you'll need to pay attention to a couple of details. First, this is an instance where you will want to discharge the CRT before disassembling anything. Next, although all 9" Mac CRTs are electrically (and mechanically) compatible, *their deflection yokes may not be*. So, unless you **know** that the yokes are compatible, the safest course is to replace only the CRT, and leave each yoke with the Mac it came with. In turn, this means that you will generally have to make a series of adjustments after replacement, because things like focus, rotation, centering, etc. may change. The next section describes how to perform these adjustments, whether occasioned by a CRT replacement, or "just because it needs them."

4.4 Leaky goop from batteries and capacitors

The SE, SE/30, Classic and Classic II all suffer from contamination of the logic board by goop leaking out of the PRAM battery and/or electrolytic capacitors. This goop is both conductive and corrosive, and can cause just about any type of malfunction, from crackly sound to boot failure. A careful visual inspection of the logic board will reveal whether contamination is a problem. Just look for telltale smudges on the circuit board near the battery and electrolytic caps. If the corrosion hasn't proceeded too far, you can usually fix these Macs by giving the board a thorough clean. If the battery is leaking (and after a few years, most are), take it out and replace it with a fresh one before doing the clean. After a clean, replace all of the electrolytic capacitors if you want to do a good job. It's not that hard (but it is tedious), and if you want that Mac to live on for many more years, replacement of all of the electrolytics is strongly recommended. That said, many Macs will spring back to life after a good clean without replacing the capacitors, but you shouldn't expect the Mac to work reliably for any extended period afterwards unless you replace them all. A good choice for replacement is tantalum capacitors, rather than the original aluminum type. Tantalum caps have nothing to leak, and they're only marginally more expensive. No matter what kind of capacitor you use, be sure to install them with the correct polarity!

As to the clean itself, first remove all simms. Then use a cotton swab dipped in isopropyl alcohol (the less water content the better), and methodically remove all the smudges you can see. In desperation, several people have resorted to using a dishwasher. It sounds loony, but it's worked amazingly well for me in a couple of very stubborn cases. No matter what method you use, be sure to dry very thoroughly before reassembling and powering up.

5.0 Basic Adjustments

Whether or not you're doing an actual repair, you may want to make a few adjustments to tune up your Mac to original factory specs. Because you'll be performing some of these operations on an opened Mac with the power on, there is a great danger of injury or death if you touch the wrong things. It's easy to avoid the danger by following a few simple

rules, though, so there's no need to be terrified into inaction. Just keep your wits about you, work carefully and slowly, and you'll be fine.

The easiest things to adjust are height, width, focus, brightness "cutoff" (more on this later), centering and power supply voltage. Also possible, but with somewhat greater difficulty, are corrections for tilted/rotated displays as well as geometric distortions in the displayed image.

There is (or should be) a cardboard insulator covering the exposed traces of the analog board. For safety, leave this cardboard in place. The locations and functions of five of these adjustments are identified with text and informative pictures.

FIGURE 4. Location of main adjustments (128K, 512K, Plus)

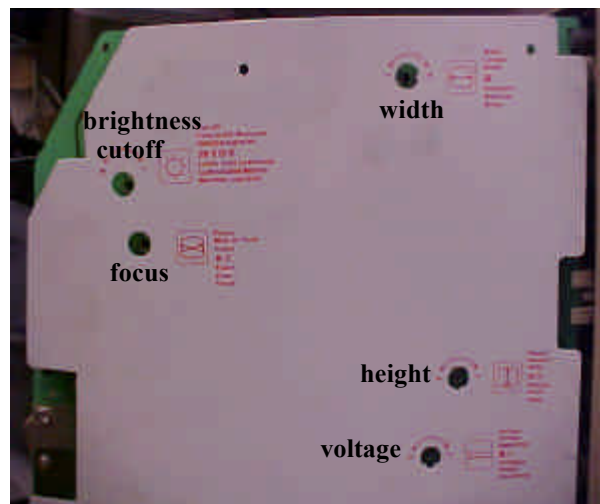

Ok, so what do these do? Width, height and focus are pretty self-explanatory, but that won't stop us from saying a bit about them. First, **EXCEPT for width**, you can make the adjustments with an ordinary, small **INSULATED** screwdriver.

5.1 Voltage

Many people tweak this control much too soon. As mentioned earlier, first fix any possible faults (such as tarnished contacts on J4), *then* tweak the voltage, and then finish up with the other adjustments. If you are making the adjustment from the cardboard-side of things, note that a clockwise rotation *reduces* the voltage; it's a bit backward from what you'd expect intuitively. If you go counterclockwise, don't go too far, or the power supply voltage will spike to high values, and probably trigger an overvoltage "crowbar" protection circuit that's built into the power supply (see the Appendix for more details on what this means).

Again, you can measure the power supply voltages without opening up the Mac by probing the appropriate pins of the 19-pin external floppy connector. You'll find +5v on pin 6,

+12V on pins 7 and 8, and -12V on pin 5. Clip onto the threaded standoffs that straddle the connector for a good ground. If your voltmeter's probes are too fat to make good contact, a paper clip will usually do the trick.

FIGURE 5. External floppy connector

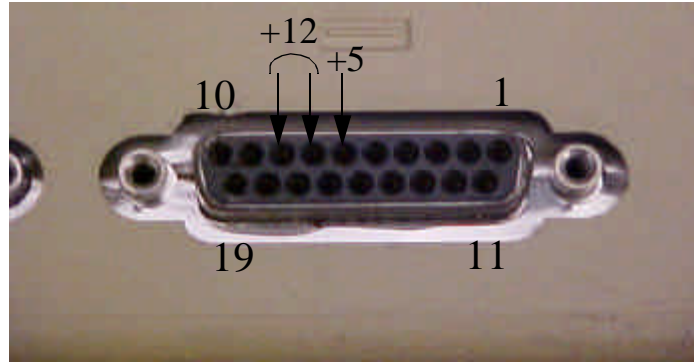

Adjust the +5V line to 5.00V, then verify that the +12V line hasn't been forced too far from +12 (it should be below 12.75V, and above 11.9V). It's probably not a bad idea to make these measurements both cold and hot, to make sure that there's no thermal drift to speak of.

5.2 Height and Width

If you want the screen to provide true WYSIWYG so that 1" on the display corresponds to 1" in real life, then its dimensions must be precise, or 4.75" x 7.11", to be more exact (that's 342x512 pixels at 72 pixels per inch). Unlike the other four adjustments, adjusting the width requires a hexagonal tool made of a **NONCONDUCTIVE, NONMAGNETIC** material. You can get these tools at places like Radio Shack, where a suitable one is sold as a tuner alignment tool. You can make a serviceable one out of a whittled down wooden chopstick or some similar material. If you use a cheap chopstick, you don't have to do much work at all. Cheap chopstick wood is soft, so tapering it enough to allow gently jamming it into the core of the control is usually good enough. It will conform to the shape of the core well enough to do the job.

The reason for the nonconductivity requirement is that the control is actually a ferrite core inside an inductor carrying large alternating currents. The AC field would induce large currents in a conductive tool, and make it get incredibly hot very quickly, to say nothing of invalidating the adjustment. At the same time, the increased strain that this places on the circuits could cause damage. So, wood or plastic it should be. Once you have the tools, you can save time by tweaking the height to 4.75" and then adjusting the width until diagonal rows of raster dots are at right angles to each other. A piece of paper or a floppy disk or any other handy object with right angles will do as a good template for this purpose.

If you don't care about WYSIWYG, then just making the dots at right angles is good enough to preserve proper aspect ratio.

If the dimensions change dramatically as you vary the brightness, there may be a problem with the high-voltage circuitry. Poor HV regulation is indicated if the dimensions increase appreciably as you increase the brightness.

5.3 Focus

Adjust the focus with the brightness set low. Tweak the focus control until the raster dots are the smallest. Some compromise may be necessary, as the ideal setting may be a little different for dots near the center than for those at the edges or corners. Once you've set the focus, check it as you crank up the brightness to the operating value. A substantial loss of focus is usually a sign of some problem with the high-voltage circuitry.

5.4 Brightness Cutoff

This control effectively sets the minimum brightness. If set improperly, the maximum brightness can be high enough to cook the screen, and the minimum brightness may be too high to render black correctly. It's easy to set: Crank up the ordinary brightness control to the maximum value. Adjust the cutoff control until the borders around the standard display area glow (you'll see what I mean), then back off until they just go black. Then reduce the brightness control to the value you plan to use.

5.5 Centering

Warning! This adjustment puts you perilously close to dangerous territory. It is highly recommended that you wear gloves and thick-soled shoes. Keep one hand in your pocket at all times, and use only well-insulated tools. Avoid contact with the yoke windings in particular, and with any exposed metal in general. *Lethal voltages are present.*

There is no electrical control to accomplish centering. There are two, flat magnetized rings around the neck of the CRT that you rotate to move the raster around. Larry Pina calls them "purity rings" (one of the few errors he makes; purity rings are used in color displays to adjust color purity). These rings are just called plain old centering rings. To effect adjustment, rotate the tabs (called, appropriately enough, centering tabs; there are two -- one for each ring) until you're happy with the centering. The handle of an old plastic toothbrush is fine for making this adjustment while keeping your hands well away from danger.

FIGURE 6. Centering rings and tabs

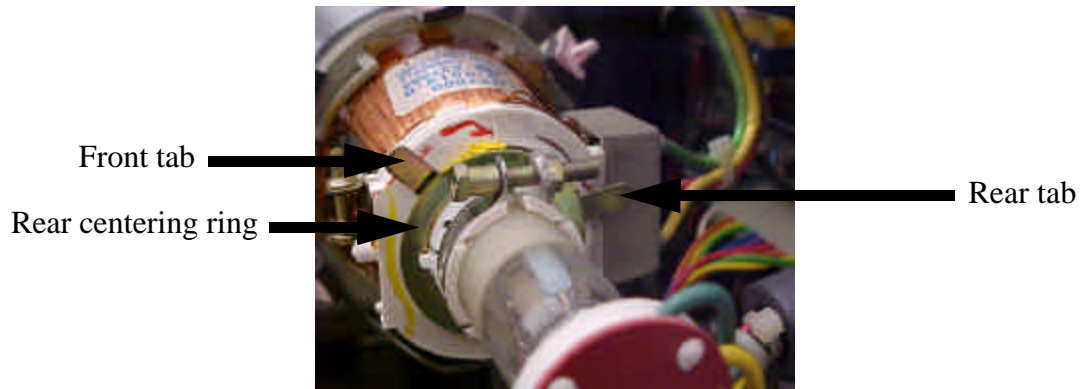

5.6 Rotation

If the raster needs rotation to set things right, you'll need to rotate the entire yoke; the display rotates in lock-step with it. First **UNPLUG** the power cord. With the Mac **UNPLUGGED**, loosen the bolt on the clamp just behind the centering rings. Next, grab the yoke and try to rotate it. It's lightly glued to the CRT, so you'll have to twist back and forth to work it free. Make sure that the yoke remains snug against the bell of the CRT. Once you've done that, you're ready to adjust it. It is best to do this by alternately powering up the Mac to observe the raster, then **UNPLUGGING** the Mac and rotating the yoke by your best estimate of the correction needed. Repeat as necessary to converge on the result you want. Then, with the Mac **UNPLUGGED**, carefully tighten the bolt until it just prevents free rotation of the yoke. Do not overdo it, or you run the risk of cracking the neck of the CRT (either right away, or as the temperature cycles). Just a little snug is all you need.

5.7 Adjustment for Geometric Distortion

In rare cases, the raster will be noticeably un-rectangular. As with centering, there is no electrical adjustment to correct for this geometric distortion. Small square permanent magnets arrayed in a ring around the yoke provide fine adjustment of geometry. They're (supposedly) glued in place, so first you'll have to rotate them hard enough to break clear of the glue. As you do so, you'll notice changes in geometry. It's probably a good idea to mark or otherwise note their starting positions before fiddling with them, just in case it turns out that you can only make things worse.

As you'll be making these adjustments most likely with the Mac powered up, work carefully to avoid getting near the actual yoke windings, or otherwise coming into contact with any exposed conductors. Again, insulating gloves and thick-soled shoes are a real good idea, as is conforming to the practice of keeping one hand in your pocket at all times.

FIGURE 7. Geometry adjustment magnets (five visible; eight total)



Geometric distortion so large that it can't be corrected with rotating these magnets is indicative of a serious problem, generally with the yoke or flyback.

After you've finished, a little dab of hot glue or loctite to keep the magnets in place is a good idea.

6.0 Working around the High Voltage Parts

On occasion, you may need to disconnect the CRT from the analog board. For example, you may be swapping out either the CRT or the analog board. Or more commonly, you might be replacing the flyback transformer. In all of these cases, you'll need to disconnect the high-voltage lead from the anode receptacle in the CRT. If you don't want to get shocked in the process, you'll need to discharge the CRT.

FIGURE 8. Anode cap, anode receptacle (“button”), and grounded CRT mounting band

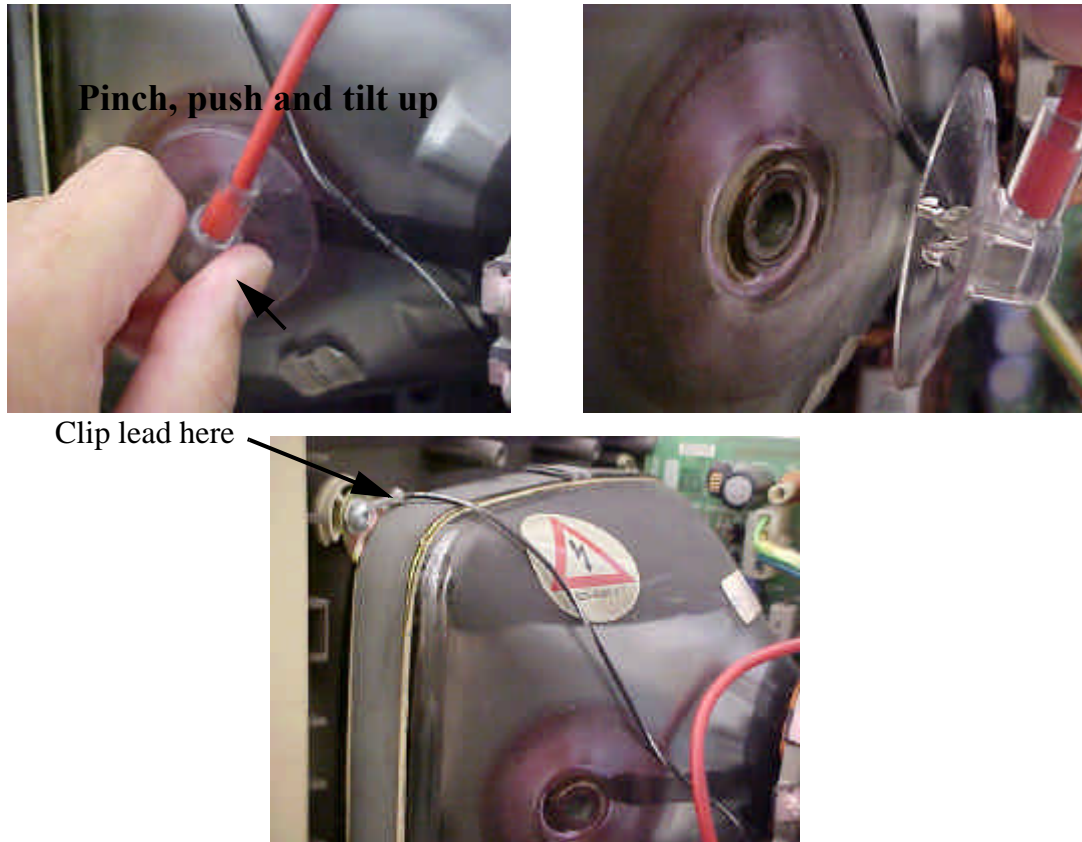

To discharge, first clip a wire onto the terminal that connects directly to the protective band around the CRT, as shown above, to make the grounded connection. Next, grab the anode cap and tilt it to open up a small gap in which to insert the other end of the grounded lead. You may also carefully slide a thin (and grounded) tool underneath the cap without tilting, in case you are working overtime to avoid even the remote possibility of getting zapped. Some online advice tells you to use a resistor in series with the grounded clip to limit peak currents. However, you need physically long (inches long) resistors, or else the HV will just arc across the resistor. For a compact Mac, a resistor is completely unnecessary, so don't waste your time locating a true HV resistor and connecting one up.

When you discharge a charged-up CRT successfully, you'll hear a little *snap*. Leave the connection in place for a solid minute if you want to discharge the CRT more fully.

To remove the anode cap altogether, first pinch **hard** with thumb and index finger, as shown in the first picture above. Use of pliers or similar tool is *not* recommended -- its jaws may damage the insulation. While pinching, push with your thumb toward your index finger, and simultaneously tilt upward with the same thumb. That should release one of the two fork-like clips that holds the cap inside the anode cavity (see the second photo above). Then slide the cap in the opposite direction to release the other clip, and pull out.

Finally, inductor L5 provides ac isolation between the CRT and the 12V filament supply.

The video circuit is very robust, and has no common failure modes.

7.2 Horizontal Circuit

The TTL-level horizontal drive signal from the main logic board is inverted by open-collector NAND U2 (here connected as a simple inverter, with pullup resistor R26). The inverted signal then feeds a small driver transistor Q6, whose output drives the horizontal output transistor Q3 through isolation transformer T2. Components R12 and C12 are snubbers that dampen voltage spikes appearing across the primary of T2 during turnoff of Q6.

As with nearly all CRT-based displays, the high voltages in this circuit are all byproducts of horizontal deflection, which explains why flyback transformer T1 has so many outputs. Pin 2 drives the horizontal deflection yoke, and C14/CR10 produce from the signal at pin 7 the 30V supply voltage used by the video amplifier. A special tap (with a high voltage rectifier buried inside the flyback) provides the ~12kV 2nd anode CRT potential. Checking the HV rectifier requires a special tester, because it is actually a series stack of numerous lower-voltage units, and ordinary ohmmeters simply don't apply enough forward bias to turn on that many diodes in series. As with any component, this rectifier can fail. However, I have never seen a Mac with a dead HV rectifier. The common failure mode is for the flyback to develop shorted turns.

The schematic for the horizontal circuit is as follows:

FIGURE 10. Horizontal sweep and high voltage circuit

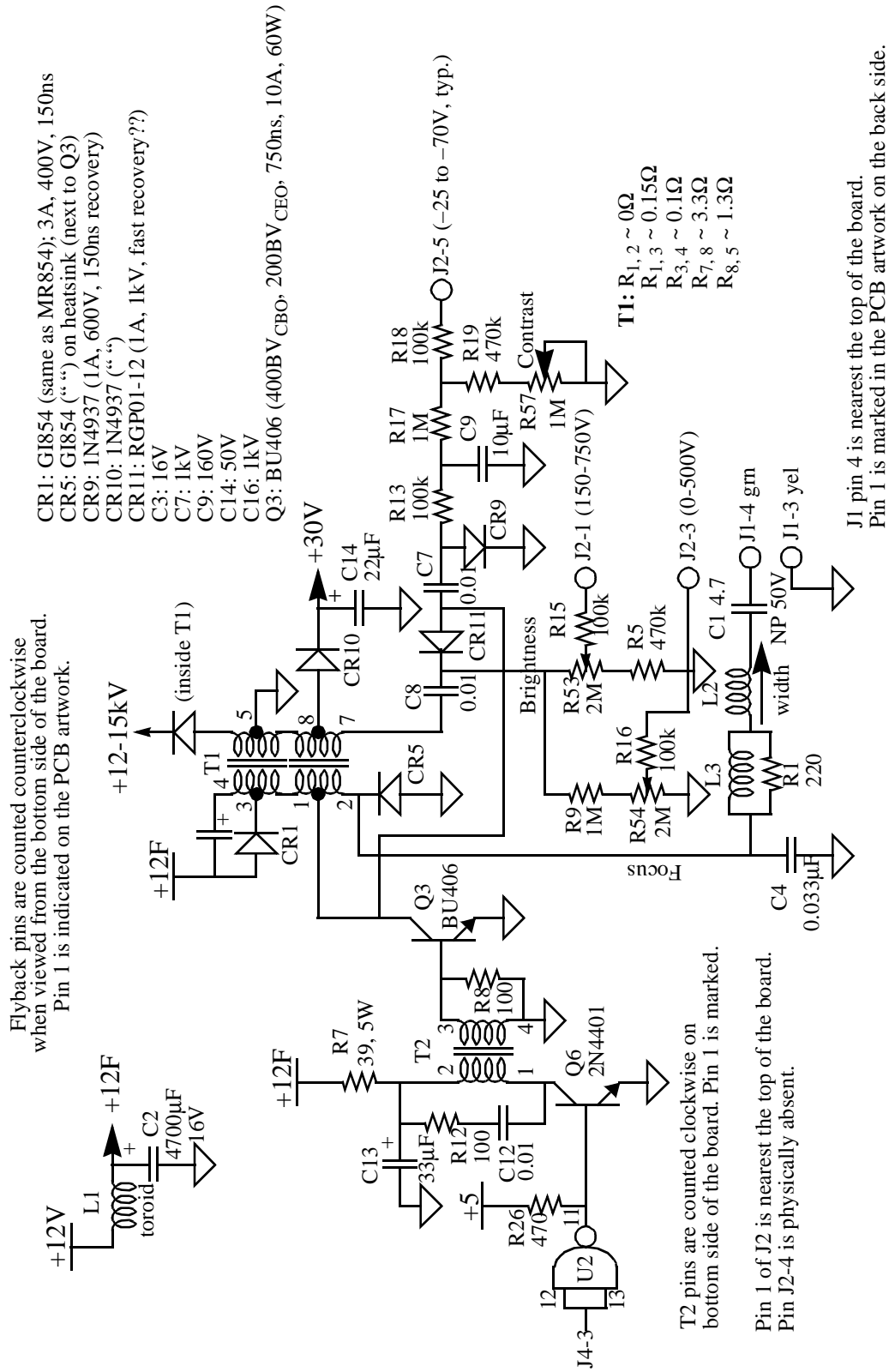

The horizontal windings of the yoke have a low DC resistance (~0.2 ohms). You should measure an infinite resistance between the horizontal and vertical windings.

The flyback transformer T1 may be checked out with an ohmmeter for basic functionality. Approximate interwinding resistances are listed on the schematic, and should be used only as a rough guide. Suspect failure only if the values you measure are very different from the ones in the schematic. (When testing, also verify the proper *lack* of continuity between windings that should not be connected.)

As mentioned in the main article, be sure to use a **nonmagnetic, nonconductive** hex tool to adjust L2's core. Width increases as the core is withdrawn from the windings, and is a minimum when the core is centered in the windings.

There is no adjustment for horizontal linearity, but it is sensitive to L3 and R1, among other things. Try fiddling with those if you are sufficiently unhappy with the linearity.

7.3 Vertical Circuit

Compact models developed after the Plus use the ever-popular TDA1170 IC for the vertical deflection circuitry, but the classic Macs use an equivalent circuit made out of standard parts and a boxload of discrettes:

FIGURE 11. Vertical sweep generator

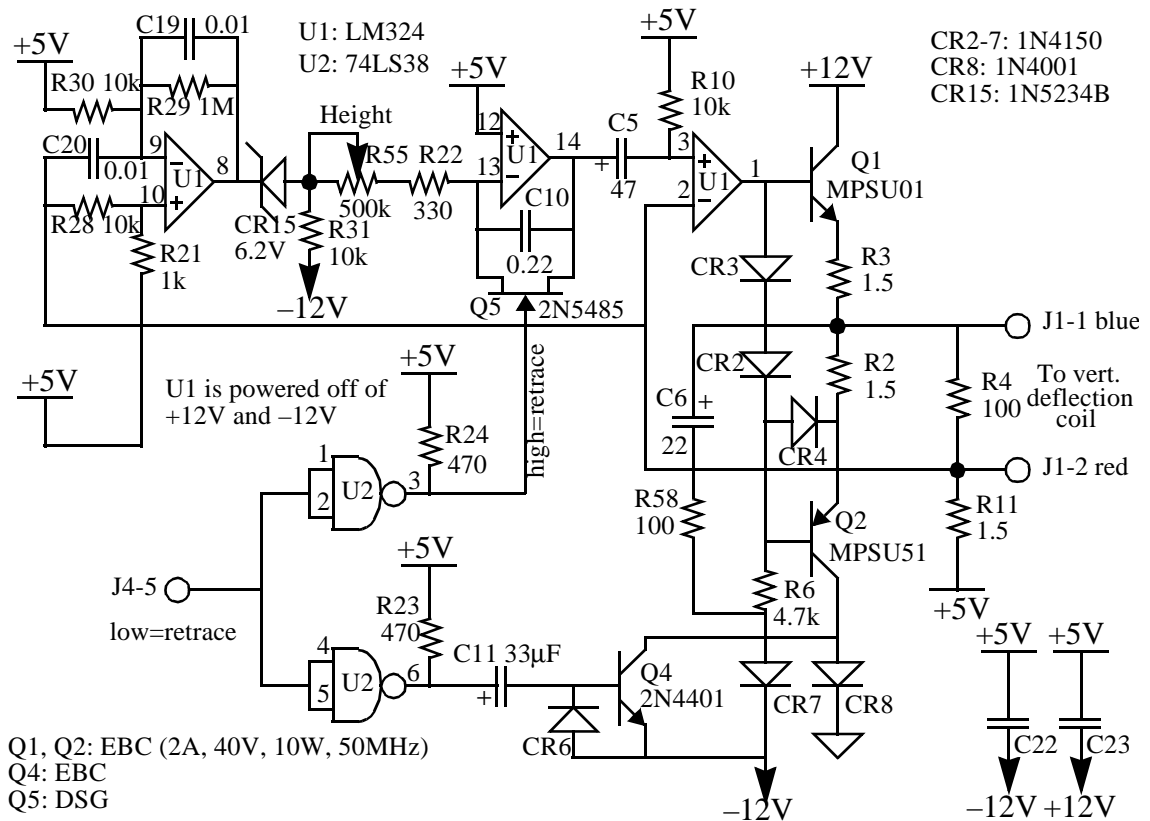

The asymmetry in the current-handling capabilities of the various power supply voltages leads to somewhat idiosyncratic circuit design here. The vertical yoke is referenced to the +5V supply instead of to ground, and the driver circuitry swings above and below this value.

The aim of all magnetic deflection circuits is to cause (to first order) a linearly increasing (sawtooth) current to flow in the yoke to create a linear deflection. In this circuit, feedback is used to produce this condition. The voltage across R11 is proportional to the current flowing in the yoke, and the voltage at J1-2 is therefore a measure of yoke current, offset simply by 5V. The third op-amp compares this current signal to the sawtooth voltage generated by (resettable) integrator formed by the middle op-amp, and adjusts the base drive of Q1 and Q2 accordingly to maintain equality.

The height is adjusted by varying the RC time constant of the integrator, accomplished here by tweaking trimpot R55.

Resistor R4 is a dummy load that keeps the loop happy even if the yoke is disconnected or otherwise open-circuits.

The incoming vertical sync signal at J4-5 is normally high during sweep. It goes low when the sweep is to reset. The top inverter-connected NAND gate activates integrator reset switch Q5, zeroing out the charge in the integration capacitor C10. This action forces pin

14 of op-amp IC U1 to go to 5V. After the switch is opened, the integrator ramps linearly up from 5V.

The bottom inverter activates Q4, effectively increasing the negative rail for the output buffers to -12V from ground for a brief interval.

The vertical deflection yoke measures about 8 ohms or thereabouts at DC, and should show no continuity to the horizontal deflection windings. As with other such measurements, only gross departures from the nominal DC values should be considered cause for suspicion.

7.4 Power Supply Circuit

As mentioned earlier, another Achilles heel of the classic Macs is the switching power supply, specified to provide a maximum output of something like 60-65 watts. Unfortunately, the original designer underestimated the special demands that switchers place on components (such as filter capacitors and rectifiers), especially when there is no fan to keep things cool. As a result, the unit is underdesigned and prone to failure.

The power supply may be decomposed into two main modules. One simply takes in 120VAC and produces a raw, $+170\text{V}$ unregulated source. The second converts this high voltage into three regulated DC outputs: $+5$, $+12$ and -12V . Only the $+12\text{V}$ output is actually regulated directly; the rest are slaved to the $+12\text{V}$ output through transformer turns ratios. A linear regulator IC on the motherboard produces a -5V output from the -12V produced by the main power supply.

The first module takes the signals from all three terminals of the AC power line, and filters them through line filter LF2, which is trifilar wound on a toroid. A fuse and spike-suppressing capacitor C38 protect the unit from gross faults. One more line filter, LF1, with R61, C33 and C37 complete the functions of protection and EMI suppression ahead of the on/off switch. Thermistor R39 limits surge currents through the bridge at powerup. Capacitors C35 and C36 filter the output, and bleed resistor R41 improves safety by discharging the deadly filter capacitors when the computer is turned off. This part of the circuit is very reliable, and has no known pathological failure modes.

FIGURE 12. Raw 170VDC power supply

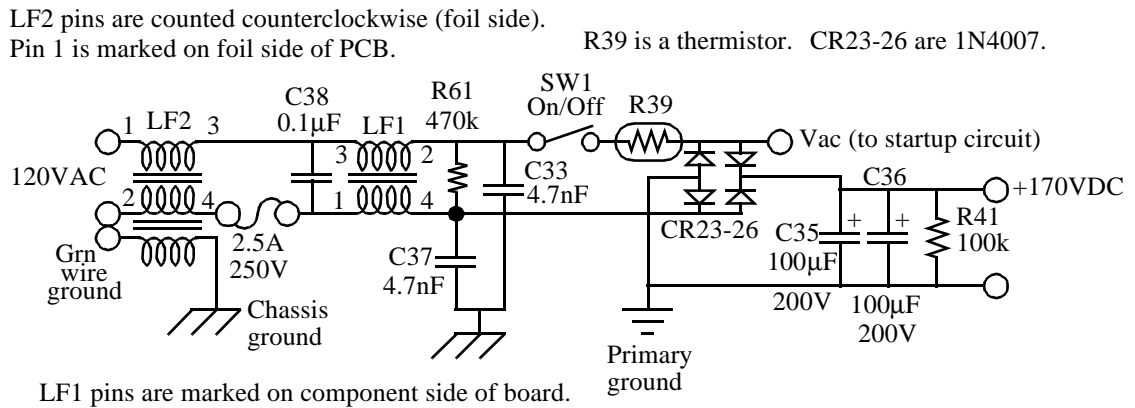

The switching power supply proper has three different subparts. One is a feedback controller, another is the actual switching converter, and the final is an array of output rectifiers and filters. The latter two subcircuits are where the most frequent failures occur.

First, here's the control circuit:

FIGURE 13. Feedback control circuit

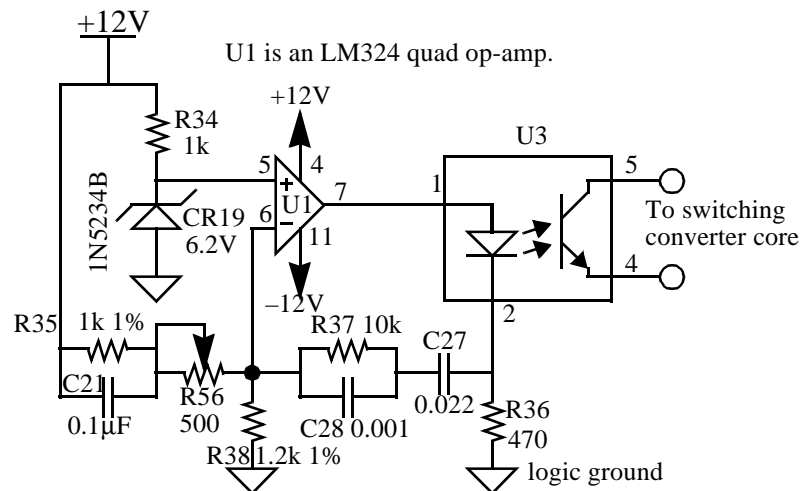

The feedback control circuit monitors the +12V supply voltage through a voltage divider comprising R35, R56 and R38. This divided-down voltage is compared with a 6.2V zener diode-derived reference voltage (from R34 and CR19). The system tries to maintain equality of the voltages presented to the input terminals of the op-amp by driving the switching converter more or less hard as necessary. An optoisolator (U3) couples the control circuitry, which is all referenced to digital ground, to the core switching converter, which is referenced to primary ground. Resistor R56 (located just above the speaker) allows fine adjustment of the output voltage. Stability of the feedback system is assured by C21, R37, C27 and C28, which together constitute a combined “lead-lag” compensator (no need to worry if this term means nothing to you; I’ve never seen a failure of this part of the power supply).

If the +12V supply voltage is too low, the LED inside the optoisolator is driven with less than normal current. This, in turn, reduces the current through the optoisolator's transistor, which ultimately commands the switching core to increase its output. The opposite happens if the supply voltage is too high. This inverse relationship between LED drive current and power supply output can be understood studying the schematic of the switching converter proper:

FIGURE 14. Switching converter core

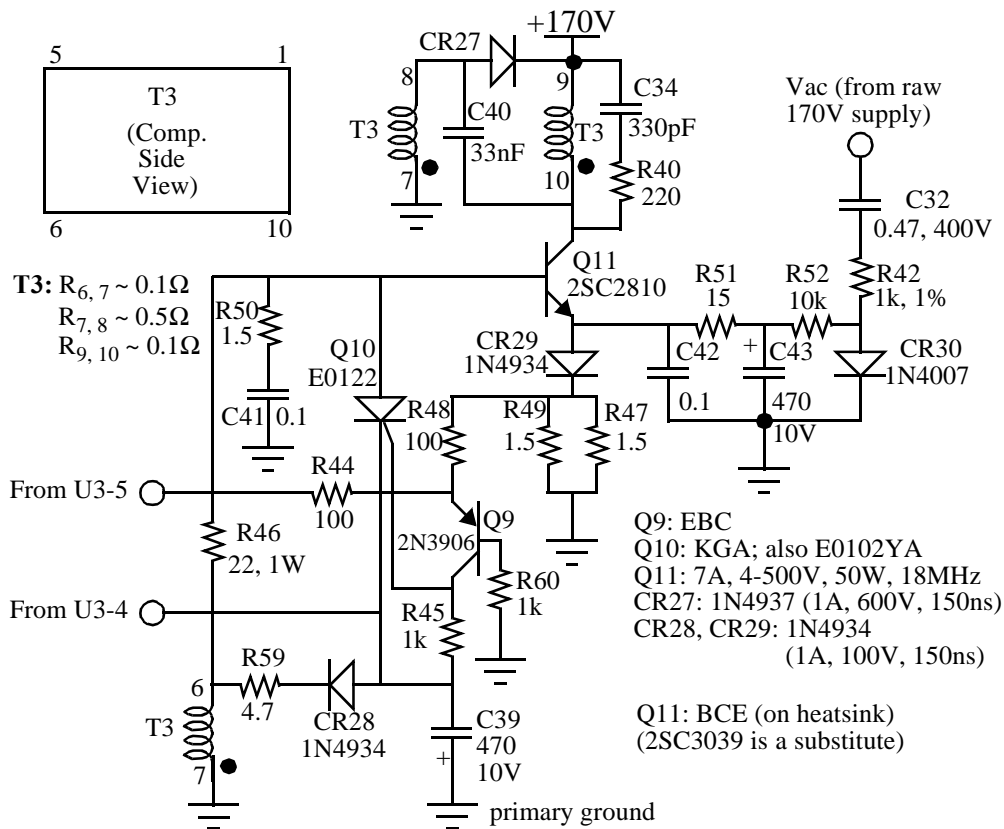

Transistor Q11 acts as a switch. When it turns on, the current through the primary of T3 (pins 9 and 10) starts ramping up, coupling energy to numerous secondary windings (only one of which is shown in this schematic). One secondary winding shown in the figure (T3-6) is connected to the base of Q11 (through R46) with a polarity that provides regenerative (positive) feedback, causing Q11 to latch, and assuring continued charging of the output. As current builds up, the voltage at the top of R47-49 rises, causing more and more current to flow through Q9, and a consequent increase in the voltage drop across R45. Eventually SCR Q10 turns on, shorting the base of Q11 to a negative rail generated by the secondary winding shown (pins 6 and 7), after rectification by CR28 and filtering by C39. The regenerative feedback by T3-6 acts to pull charge rapidly out of the base of Q11, causing a fast turnoff once initiated. This action also recharges C39 at the same time.

Capacitor C40 feeds the collector voltage of Q11 to T3-8, which is coupled to T3-6, closing a feedback loop that produces oscillation with a switching frequency in the low 10's of kHz range.

The voltage regulation loop works by varying the time at which SCR Q10 turns on to shut off Q11. When the 12V supply voltage has reached the correct value, the feedback control circuitry steals less current away from transistor Q9, allowing more current to flow through R45, causing the SCR to turn on sooner. If the 12V supply voltage is too low, turn-on of the SCR is deferred, allowing more charge to transfer to the output to boost the voltage.

Spikes across the transformer windings are snubbed by series RC networks R40-C34 and R50-C41.

This type of circuit suffers from a “chicken-and-egg” startup problem: if all outputs are zero, they stay zero. To get things going in the first place, some of the raw ac line voltage is coupled into this circuit through C32 and R42. It is rectified by CR30 and filtered by R52, C43, R51 and C42. The resulting modest negative voltage pulls the emitter of Q11 downward enough to turn it on and get things going. Once the switching core has started to operate, Q11’s emitter voltage rises enough to make the startup network irrelevant from that point on.

Three of the five secondary windings of T3 are rectified and filtered to provide the +5V, +12V and -12V outputs, as shown in the following schematic:

FIGURE 15. Power supply output and crowbar circuitry

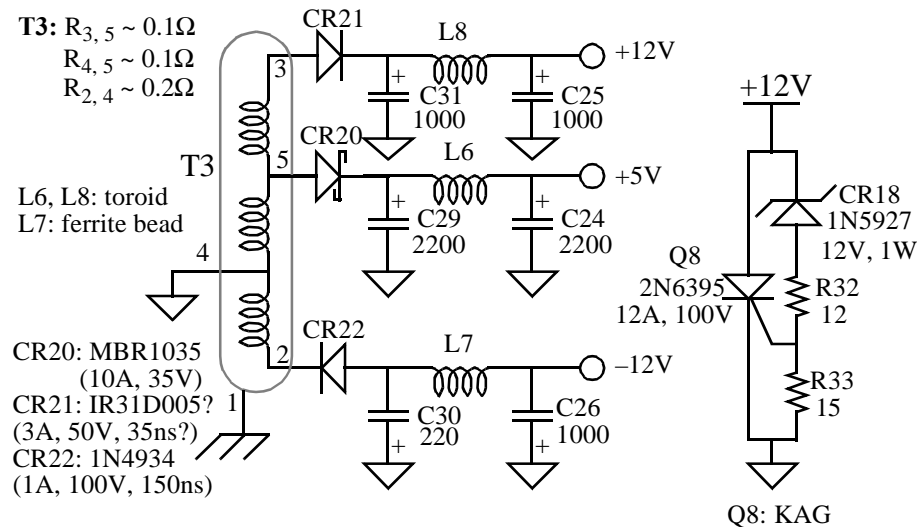

All filter capacitors are rated 16V.
CR20, CR21 and Q8 are mounted on heatsinks.

All three outputs are filtered with textbook C-L-C “pi” networks. Adjust the voltage trim-pot R56 so that the +12V output (as measured at the external floppy connector) lies between 11.9V and 12.75V, and the 5V output lies between 4.85 and 5.15V. Inability to get both the 12V and 5V outputs within spec can be caused by a failure or drift in components, but most often is caused by simple deterioration of J4’s connector contacts, as described earlier. Simply cleaning the power harness contacts, or resoldering where they connect to the circuit boards, fixes 90+% of such problems.

The computer is protected against gross regulation failures that would lead to excessive supply voltages. Twelve ampere “crowbar” SCR Q8 turns on and purposefully short-circuits the 12V supply if there is a dangerous overvoltage (on the order of 15%) on the +12V supply, indicating a regulator failure (or misadjustment of R56). The resulting short circuit forces the power supply into a self-protective current limiting mode. Q8 is a 2N6394 in some versions; the only difference is that it is rated at 50V instead of 100V. Both SCRs will work fine.

After the crowbar has been activated, the power supply periodically tries to recover, emitting a characteristic “whup-whup-whup” sound as long as the overvoltage/current limit problem persists. To make sure that the problem is not caused by an improper setting of voltage control R56, turn it to the most *clockwise* position (when viewed from the foil side of the PCB -- that’s the side that is covered with the cardboard insulator) to minimize the output voltage setpoint. If the “whup-whup” sound is still heard, it indicates a major problem elsewhere.

8.0 Connectors

There are three connectors on the analog board. Most of the connections have been documented piecemeal in the previous sections, but it’s handy to have everything in one place for quick reference:

FIGURE 16. Connectors as viewed from the component side of the analog board

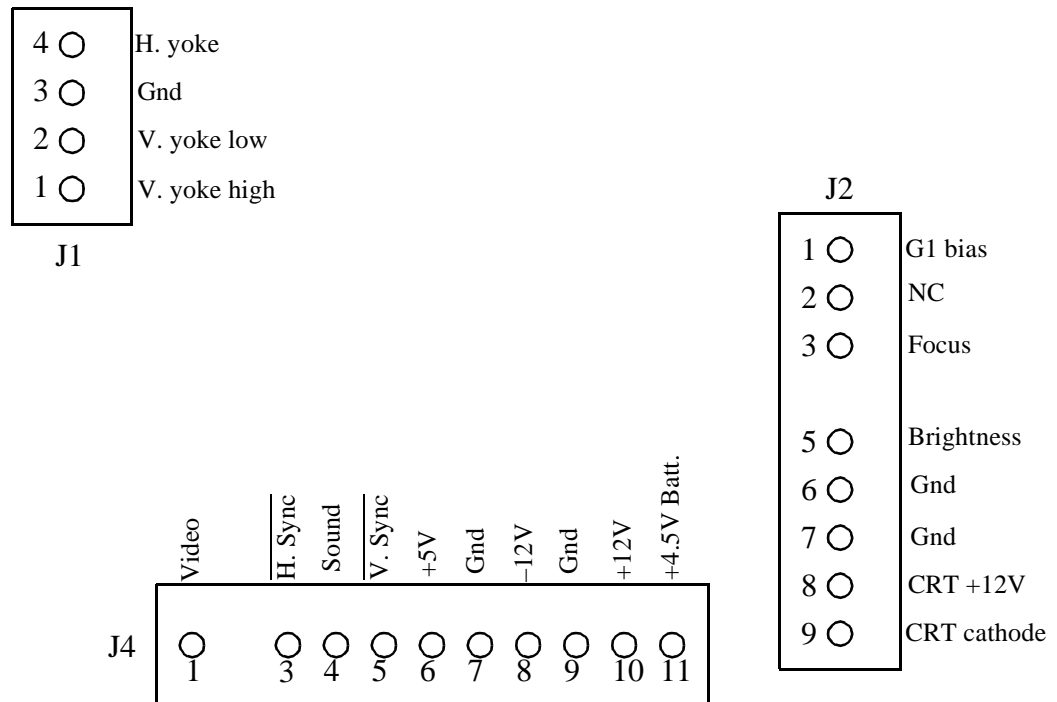

9.0 Appendix 2: More Random Info

9.1 Using PC and Surplus Parts with Classic Macs

Finding parts for classic Macs can be difficult at times, so it's occasionally useful to know how to adapt components intended for the PC world to fix a Mac.

9.1.1 Monitors

The 9" CRT in the classic Macs is definitely cute, but it is just as definitely small. Several manufacturers once made adapters and monitors that not only expanded the screen's size, but also permitted more text to be displayed at any given time. Unlike those products (which are no longer available), the modification described here only gives you a larger screen, period. It's the electronic equivalent of putting a magnifying lens in front of the existing CRT.

Most older "TTL" PC monitors are at least 12" in size, and the added area is significant. Unfortunately, they're also often green or amber, and most people find them a little hard on the eyes when used with a Mac. If you can locate a black and white unit (somewhat rare), you'll be a lot happier with the results. You can also interface to a modern color monitor.

Beyond that consideration, there are two technical issues to contend with. One is that the Mac produces horizontal sync and video signals that are logical inverses of what TTL PC monitors expect (the vertical sync signal is just fine, however). The second consideration is that the ~22kHz horizontal sync frequency generated by the Mac is substantially higher than the ~16kHz expected by old PC monitors, so you'll almost certainly have to fiddle with the timing network in the monitor to insure synchronization (this issue usually disappears if you are interfacing to a multisync monitor, but the instructions here don't give the pinouts for that). Inside some monitors, there is a small trimpot to adjust the frequency. In others, you will have to change a resistor. Clearly, such a modification is **only for those with advanced circuit skills**. Schematics of the monitor are a big help, too. In many old monitors, a 555 timer IC is used as the horizontal oscillator. Look for one (there may be two) and, in particular, look for precision 1% resistors (typically there are two of them) and/or a precision capacitor near the 555. These are almost certainly the timing elements. Increasing the frequency by a factor of about 1.38 requires a reduction in RC product of that same factor. The easiest method is probably to place a potentiometer in parallel with the larger of the two precision resistors. Keep the leads absolutely as short as possible to avoid interference from other signals generated nearby; you can fry the deflection circuitry if you do not observe this precaution. Choose a potentiometer whose maximum resistance is about 5x larger than the fixed resistor it is to parallel. That should give you enough adjustment range to get the monitor to lock to the Mac's higher sweep frequency. Set the pot initially to the maximum resistance (and **never** allow the pot to go too low in value, or you will once again risk frying the works; always start the pot in the position of maximum resistance, and work down, taking care not to go too far), and then power up the monitor. Adjust the pot until the display stabilizes. As an additional check, turn the moni-

tor off then on again, and verify that lock is maintained. If not, readjust the pot and repeat the test.

For the necessary signal inversions a cheap 7404 or 74C04 hex inverter IC does fine; just be sure to include a power supply bypass cap, and ground all unused inputs if you use the 'C04 CMOS inverter (an alternative is to connect the extra inverters in parallel with the main ones). The inverted and other motherboard signals should be wired to a female DB-9 as follows:

Motherboard (J4) Signal		DB-9 Pin
1	Video	7 (after inversion)
3	Hsync	8 (after inversion)
5	Vsync	9
7, 9	Gnd	1, 2, 6

9.1.2 Mice

Remarkably, **old** PC bus mice turn out to have **all** the same internal workings and output signals as classic Mac mice. All that is needed to convert for use in Macs is to substitute a male DB-9 Mac connector for the DIN-9 PC connector as follows:

DIN Pin (PC)	Function/Signal	DB-9 Pin (Mac)
1	+5V	2
2	XA/left	4
3	XB/right	5
4	YA/up	9
5	YB/down	8
6	left button	(7)
7	mid button	(7)
8	right button	(7)
9	ground	1

Note that any or all of the PC mouse buttons can be used as the single Mac mouse button. I've wired all the buttons together in all the conversions I've done, as shown in the table above, so that clicking any one of them makes something happen.

9.1.3 Keyboard vs. telephone cables, and keyboard notes

Extremely important: **Never** substitute a standard telephone cord for the keyboard cable! It's hard to do this in most cases, because the RJ-11 phone connector is normally too wide for the Mac. But some aren't. The Mac deviously reverses the connections on one end, just to assure maximum incompatibility with telephone cables. But the situation is worse than mere incompatibility: If you make the mistake of using a standard telephone cable, you will apply power to the keyboard in **reverse polarity**, virtually assuring the destruction of either the keyboard or the Mac (or both)!

You can modify a standard telephone cable for Mac use by cutting off the connector on **one** end, and replacing it with a new RJ-11 connector in reverse order. You may have to file down the sides to fit.

Keyboards from any classic Mac can be used on any other classic Mac (defined as the 128K/512K/Plus), contrary to the assertions of some. I've tested this personally with all models of classic Macs.

PC keyboards are completely incompatible with Mac keyboards (both the keycodes and hardware interfaces are totally different). There is no practical way to modify them for Mac use, so just abandon this idea altogether.

9.1.4 Floppy Drives

PC floppy drives are so different from those of the Mac that there is no practical way to convert them into Mac drives. Both the format of data storage on the disk, as well as the nature of the interface, are completely different. In particular, Mac drives have more “smarts” built into them, containing much of the circuitry found on floppy controller cards for PCs. Also, classic Mac drives vary their rotational speed (spinning faster when accessing data on the outer tracks, in order to maintain a roughly constant linear data density), but PC drives run at a fixed speed and have no means for varying it. So, just give up the idea of converting a PC floppy drive for Mac use. The difference also explains why you can never read 800K disks in a PC floppy drive. Software, no matter how cleverly written, cannot overcome the fundamental hardware incompatibility. The Apple Superdrive (FDHD, for “floppy disk, high density”) is a complex widget that manages to accommodate 800K/1.4M Mac formats, as well as 1.4M PC formats. But standard 1.4M PC floppy drives are much less capable mechanisms, making the transfer of data from old Macs to PCs through 800K floppy disks (“sneaker net”) impossible.

Alas, there does not appear to be any simple way to use Superdrives on classic Macs. Connecting a Superdrive to a classic Mac merely gives you another 800K drive; the extra capability is ignored. A company called Applied Engineering once made a unit called the AEHD+, which did impart 1.4M capability to old Macs such as the Plus and original SE (except that you could not boot from the AEHD+). It accomplished this by integrating a special controller card, working in tandem with special driver software. The AEHD+ is no longer made, and is rare enough not to show up too often even at places like eBay, unfortunately. If you do locate one, make sure that it is the AEHD+, and not just the AEHD. The latter is a plain old 1.4M drive for use with machines that already support such drives. When connected to a Plus, an AEHD will simply behave as an 800k drive.

Another option is to find an old Floptical drive (made by Insite Peripherals; other companies also made them under license, or rebranded them). This SCSI device was sold as an accessory for Macs, and was also an option on some early SGI workstations (which can be a good source of floptical drives on the surplus market). The Floptical not only allows the Plus to use 1.4MB floppies, but also provides 21MB storage capability on special floppies (good luck finding them, though).

Contrary to popular belief, an 800K drive can be used on a Mac 512K without first performing a ROM upgrade (or any other hardware modification), as long as the HD20 init is installed. This init patches the system file to enable the HFS filing system. The Mac 512KE (and the Plus) already has this code in its upgraded ROM. The HD20 init can be downloaded from a number of sites, including Apple's.

Occasionally, you may encounter problems after installing 800K drives in the older models. Cutting pin 20 of the floppy cable often solves many of these problems. The signal on this pin controls the motor speed in 400K drives. 800K drives do not use this signal, but some revs of 800K drives may be confused by its presence.

If you find that the eject motor of a newly installed 800K drive runs continuously, cut pin 9 of the floppy cable. This pin supplies $-12V$, which is used only by 400K drives. Mid-production runs of 800K drives ignored this wire. However, later 800K drives evidently use this pin for some other purpose (perhaps for production test?), and connecting $-12V$ to it makes those drives misbehave.

9.1.5 Floppy drive head connections

Heads rarely go bad electrically (almost always, they fail because of various forms of mechanical abuse). But, it's possible. Luckily, testing the heads is pretty easy to do with an ohmmeter. All resistances given in the following are very approximate:

R23: 50 ohms

R24: 25 ohms

R25: 35 ohms

R34: 30 ohms

R35: 40 ohms

R45: 10-15 ohms

Pin 1 is not connected to anything.

Only gross departures from these approximate resistance values (e.g., open circuits) should be interpreted as a problem.

The connector for the bottom head on a dual-head drive (800K/1.4M) has terminals labeled 1-5 going from left to right when viewed with the edge fingers facing you and pointing down. The connector for the top head has terminals arranged as the mirror image of the bottom head's connections.

9.1.6 Using 1.4MB floppy disks in 800K drives

Since 800K floppy disks are now considered obsolete, they are less widely available than they used to be. In a pinch, you may use a 1.4MB disk in 800K drives by covering up the media identifier hole (the one without the plastic write-protect slider) with a piece of tape. There's a lot of lore about this operation resulting in unstable data, etc., and it does have a basis in fact: 800K disks require less magnetic force to write, so 1.4MB disks are written

with somewhat less than optimum strength by 800K drives. However, the media are close enough in characteristics that this is usually not a real problem *unless the 1.4MB floppy has previously been written on by a 1.4MB drive*. The weaker write fields of 800K drives may not be sufficient to reliably over-write existing data (**including formatting data**). So, use only *virgin* (not just empty) 1.4MB floppies in an 800K drive. If you follow this rule, you'll have few (if any) problems. If you have a good bulk eraser, that can effectively "re-virginize" floppies, making them better candidates for this procedure. Nevertheless, it's still best to consider this tape trick a temporary hack for emergencies.

9.2 How to Upgrade the Mac 512K to 1MB (and beyond?..)

These days, most owners of 128K/512K Macs prefer to keep their Macs in their original (and now, more valuable) condition; in fact, there's even a movement toward restoration of upgraded machines back to factory-original status, to make them more collectible. This section is not for those folks.

Achtung! These instructions assume an understanding of how to remove the motherboard, how not to electrocute yourself, familiarity with proper ESD protocol and knowledge of circuit prototyping methods. If these are bad assumptions, chances are high that this particular upgrade is not for you. Even if these assumptions are correct, this upgrade is not a trivial one by any means, so it's definitely not for the faint of heart.

If that disclaimer hasn't scared you off, then let's proceed. First, here's a list of the parts you will need:

- 16 150nsec (or faster) 256kb DRAMs (standard DIP package)
- 1 74LS138 demux chip
- 1 16-pin low-profile wire-wrap DIP socket (optional)
- 1 0.1uF ceramic capacitor
- 1 1kilohm, 1/8 or 1/4W resistor
- 4 47-ohm, 1/8 or 1/4W resistors
- 1 small piece of vectorboard or similar (large enough to hold the '138, resistors and capacitor)
- hookup wire (26-30AWG)

These days, 256k RAM chips and 256K RAM SIMMs are obsolete. You should be able to find them at surplus electronics shops for almost zero dollars. I obtained mine for free at an electronics flea market. A future revision of this document will include instructions for how to modify those ubiquitous (and generally free) 256k RAM SIMMs for use in upgrading a Mac512K to 1MB (less wiring!), but the instructions that follow here assume you have individual DRAM chips.

In what follows, reference is often made to various coordinates, such as "D3" and the like. Labels for these coordinates may be found along the edges of the motherboard.

Step 1: Solder the DRAMs onto the existing DRAM chips (located at positions F5-F12 and G5-G12), "piggyback" style, except for pin 15 (CAS_b) of each added chip; leave those free. Take care to orient all the chips properly! Pin 1 of each chip should point away

from the 68000 microprocessor in the center of the board, and toward the nearest edge of the board, the same as the existing memory chips. It is important that the added DRAM chips all have the same access speed, so they should all be 150ns parts, for example, or all 120ns. Mixing speeds can cause erratic behavior. Note that the added chips only have to match each other in speed; they need not match the speed of the original 512k chips. Note also that, since overall memory timing and processor speed are controlled by a crystal oscillator, using DRAMs that are faster than the 150ns recommended value cannot, and will not, speed up the Mac in any way (this is the only other mistake of Larry Pina's that I can recall).

If the near-irreversibility of soldering chips directly onto other chips concerns you, you may wish to solder low-profile sockets onto the existing DRAMs instead. Just be sure that there's then enough room to slide the motherboard back into the chassis when the added chips are socketed!

Step 2: Very carefully bend pin 15 of each of the added chips (or sockets) with a small needlenose so that, from a side view, each pin forms a "U" shape. The idea is to have the pins up in the air a bit so that a wire running horizontally across the array of chips can connect all of the pins 15 together. Just bending a pin from its normal down position into a straight-up position is a bit risky (the pins break off easily from the body of the chip), hence the "U" bend idea. Make sure to bend each pin enough to avoid shorting to pin 15 of the chip underneath.

Now connect all the pins 15 of each row of added DRAMs together, keeping the two rows electrically separate. Leave enough wire in both cases to reach all the way to roughly chip location D3. These will be connected later.

Step 3: Locate the TSM chip, positioned at D1. Carefully and cleanly cut the traces leading to pins 12 and 13. One line is on the component side of the board, and the other isn't.

Step 4: Prepare the vectorboard as follows: Install the 74LS138 chip, and connect a 0.1uF capacitor across pins 8 and 16, keeping the leads of the capacitor as short as possible. Connect pins 4, 5 and 8 together. Then connect the 1-kilohm resistor from pin 16 to pin 6. Next, connect a 47-ohm resistor in series with each of pins 10, 11, 12 and 13. We will refer to the free ends of those resistors as pins 10R, 11R, 12R and 13R. Then, figure a way to mount this whole assembly securely on the motherboard, keeping in mind that you will eventually be connecting wires to pins 1-3, 10R-13R as well as 8 and 16 (ground and +5V, respectively). The space between location E3 and the 68000 may be a good choice. If you use a low-profile wire-wrap socket, its stiff pins might be useful in providing a stable mounting option.

Step 5: Connect pins 2 and 3 of the 'LS138 to pins 12 and 13 of the TSM chip@D1, respectively, with wires that aren't longer than necessary. Then connect pins 11R and 13R to pins 7 and 9 of RP3, respectively. RP3 is a SIP resistor pack positioned next to the DRAM array at around G5. Making connections to RP3 on the component side of the board is very difficult, so it is probably best to route two wires through the PC board via hole conveniently located pretty close to RP3, and make connections on the other side.

Try to keep these wires as short as possible as well. Next, connect pin 12R to the common pins 15 of the piggybacked DRAM row nearest the edge of the motherboard. Finally, connect pin 10R to the pins 15 connection of the other added row of memory chips. As before, keep these wires short.

Step 6: Connect pin 1 of the ‘LS138 to pin 3 of the TSG chip located at D3. Finally, get power to the ‘LS138 by connecting its pins 8 and 16 to pins 10 and 20, respectively, of the TSG chip.

Step 7: Check your work carefully to make sure there are no solder bridges, and that everything really is wired up correctly. Then reinstall the motherboard and test out the Mac. Under “About the Finder” in the Apple menu, you should see that the memory has increased to 1MB.

For reference, the “official” signal names for the connections made are as follows:

TSM-12: CASL_b; TSM-13: CASH_b
TSG-3: A19
‘LS138-10R: CAS1L_b; ‘LS138-11R: CAS0L_b
‘LS138-12R: CAS1H_b; ‘LS138-13R: CAS0H_b
Pin 15 of each DRAM is CAS_b

Note that expansion to a maximum of 4MB is possible in principle if 32 1Mb chips are used (in which case the original DRAM chips are effectively removed from the circuit), and if the address decoding is modified accordingly. However, 1Mb DIPs have 18 pins and a pinout that differs significantly from that of the 256k generation, so that particular modification is only for the truly hardcore!

9.3 Keyboard Repair

Keyboard keys have to withstand considerable abuse. Physical punishment, combined with the occasional spilled soda, can result in flaky behavior, or just plain failure. Fixing the individual keys themselves is actually straightforward; it’s getting the actual key switch out that’s the hard part. Given that difficulty, it might be worth trying a quick fix first: Some people (but not me) have had luck spraying the internal guts of the keys with WD-40 (or similar). I always just end up with a greasy mess. Others have placed the keyboard in a dishwasher! I am not so brave, but if the keyboard otherwise seems a total loss, I guess there’s no harm in trying one last desperate act.

If a quick fix doesn’t solve the problem, you’ll have to do a little more work. First, open up the keyboard and remove the circuit board. Gently pull off keycaps until you have cleared a sea of keys centered around the defective key. You may wish to start from one edge of the keyboard and work your way to the defective key. This may require the removal of lots of keycaps, but it minimizes the risk of damaging them. Keep track of where they go.

Note the four small slots at each corner of the plastic cover of the key switch. Insert a small jeweler’s screwdriver into one of the slots. While prying toward the nearest edge of

the switch, use a second screwdriver to pry that edge of the switch up a bit. Do the same operation at each of the four corners of the switch. When the switch is out of the keyboard a decent amount, gently pull it out the rest of the way by the stem that protrudes from the middle. **Warning:** There's a little spring inside, just waiting to pop out and disappear into thin air, so be prepared for it! It's *very* easy to lose.

Now that you have the switch proper out and free to work on, examine its contacts. The typical failure mode is that the contacts fatigue a little over time, and stop working reliably (or at all). Bending the contacts (carefully, and with tweezers or something similar) often solves the problem (at least for a good long time). Cleaning the contacts with a product like Cramolin or something similar may be useful in other cases. In any event, be careful not to touch any conductive surfaces with your fingers, however, or the switch contacts will eventually tarnish and fail down the road. Alternatively, replace the key or contacts using parts from an "organ donor" keyboard. You can even use rarely used keys on the same keyboard as organ donors in a pinch.

When finished with the repair, reassemble the key, being careful to replace the spring. Reinstall the keycaps and circuit board, button up the keyboard case, then test. That should do it.

10.0 Document Revision History

Rev 1.0: Initial release, allegedly Acrobat 3.0 compatible

Rev 1.1: Re-distilled to be Acrobat 2.1 compatible; fixed minor font boo-boos.

Rev 2.0: Quickly edited in an effort to make it less intimidating to the weekend hobbyist. Moved the techno-geeky schematics into an appendix, and added specific troubleshooting advice up front, with pictures. Still needs considerable polishing, but it's time to ship this puppy.

Legal stuff: If you break anything or get hurt, it ain't my fault.

And you may copy and distribute this document freely, provided that:

- 1) You distribute it in its entirety (including this legal notice), and make no alterations of any kind.

- 2) You charge nothing for it.